

Environmental Compliance Evaluation Report

Product Name : Smart Charger

Product Model : SCharger-22KT-S0, SCharger-7KS-S0

Report Number : SYBH(G)10214219

Reliability Laboratory of Huawei Technologies Co., Ltd.

(Global Compliance and Testing Center of Huawei Technologies Co., Ltd.)

No.2, New City Avenue, Songshan Lake Sci. & Tech. Industry Park, Dongguan, 523808, P.R.C

Tel: +86 769 23830808

Fax: +86 769 23837628

Notice

1. The laboratory (Reliability Lab of Huawei Technologies Co., Ltd) is also named "Global Compliance and Testing Center of Huawei Technologies Co., Ltd", the both names have coexisted since 2009.
2. The evaluation report is invalid if not marked with the signatures of the persons responsible for preparing and approving the report.
3. The evaluation report is invalid if there is any evidence of erasure and/or falsification.
4. The evaluation report is based on the quality and trustworthiness of the documents for materials, parts, and/or sub-assemblies provided by the suppliers. Huawei has established procedures to evaluate the documents in order to determine their quality and trustworthiness according to European Standard EN IEC 63000: 2018.
5. Content of the evaluation report, in part or in full, cannot be used for publicity and/or promotional purposes without prior written approval from the laboratory.

Applicant : Huawei Digital Power Technologies Co., Ltd.

Address : Office 01, 39th Floor, Block A, Antuoshan Headquarters Towers, 33
Antuoshan 6th Road, Futian District, Shenzhen, 518043, P.R.C.

Product Name : Smart Charger

Product Model : SCharger-22KT-S0, SCharger-7KS-S0

Date of Receipt Sample : 2023-01-06

Start Date of Evaluation : 2023-01-06

End Date of Evaluation : 2023-01-09

Evaluation Result

Regulation/Directive	Conclusion
EU RoHS (2011/65/EU & (EU) 2015/863) & UK RoHS	Complies
SVHC in accordance with Article 59(1) of the Regulation (EC) No 1907/2006 (REACH)	See Clause 5.2.2
Regulation (EC) No 1907/2006 (REACH) Annex XVII	Complies
94/62/EC & 2004/12/EC for Packaging Material & The Packaging (Essential Requirements) Regulations 2015	Complies
EU WEEE (2012/19/EU) ANNEX V & UK WEEE SCHEDULE 11 PART 2	Complies
EU POPs ((EU) 2019/1021) & UK POPs	Complies
2006/66/EC & 2013/56/EU on batteries and accumulators & The Batteries and Accumulators (Placing on the Market) Regulations 2008	Complies
China RoHS (Decree No. 32 of the Chinese Ministry of Industry and Information Technology)	See Annex I

Approved by Senior Engineer:

2023-01-11

Liu Chuming

Date

Name

Signature

Prepared by:

2023-01-11

Zuo Jiefan



Date

Name

Signature

Modification Record

No.	Last Report No.	Modification Description
1	N/A	First report

List of abbreviations

No.	Abbreviations	Full spelling
1	RoHS	the Restriction of the use of certain hazardous substances in electrical and electronic equipment
2	REACH	REGULATION concerning the Registration, Evaluation, Authorisation and Restriction of Chemicals
3	SVHC	Substances of Very High Concern
4	WEEE	Waste Electrical and Electronic Equipment
5	MCD	Material Composition Declaration
6	BOM	Bill of Materials
7	PDM	Product Data Management
8	Insight	Huawei Product Compliance Management Platform
9	ppm	parts per million
10	ppb	parts per billion
11	NA	Not Applicable
12	ND	Not Detected (Less than the method limits for the test lab)
13	3R	Recovery, Reuse and Recycling

Contents

1	GENERAL INFORMATION	7
1.1	APPLIED STANDARD	7
1.2	EVALUATION LOCATION.....	7
2	PRODUCT PHOTO.....	8
3	REVIEW OF DOCUMENTS OF CONFORMITY.....	8
4	ROHS EVALUATION OF PRODUCT.....	9
4.1	EVALUATION OF MATERIALS / SAMPLES.....	9
4.2	TEST ITEMS AND METHODS OF THE HIGH RISK MATERIALS.....	10
4.3	ROHS REQUIREMENTS	10
5	REACH EVALUATION	10
5.1	REACH REQUIREMENTS OF ARTICLE IN PRODUCT.....	10
5.2	REACH SVHC EVALUATION.....	11
5.3	EVALUATION OF REACH ANNEX XVII	12
6	EVALUATION OF PACKAGING MATERIAL	13
6.1	REQUIREMENTS OF PACKAGING MATERIAL FOR RESTRICTED SUBSTANCES	13
6.2	EVALUATION RESULTS OF PACKAGING MATERIAL.....	13
7	EVALUATION OF BATTERY	14
7.1	REQUIREMENTS OF BATTERY FOR RESTRICTED SUBSTANCES.....	14
7.2	EVALUATION RESULTS OF BATTERY	14
8	POPS EVALUATION	14
8.1	REQUIREMENTS OF POPS.....	14
8.2	CONTENTS OF RESTRICTED SUBSTANCES.....	14
8.3	CONCLUSION	15
9	WEEE 3R (RECOVERY, RECYCLING & REUSE) EVALUATION.....	15
9.1	PREPARATION OF PRODUCT 3R EVALUATION.....	15
9.2	WEEE 3R CALCULATION OF PRODUCT.....	16
9.3	WEEE 3R CONCLUSION	19
9.4	SKETCH FIGURE OF SAMPLE DISASSEMBLY	19
9.5	WEEE 3R REQUIREMENTS	20
9.6	WEEE 3R DEFINITION	20
ANNEX I CHINA ROHS HAZARDOUS SUBSTANCES INFORMATION EVALUATION		22
ANNEX II CONFIGURATION OF PRODUCT.....		22

1 General Information

1.1 Applied Standard

Applied Product Directives & Standards : 2011/65/EU & (EU) 2015/863 (EU RoHS) & The Restriction of the Use of Certain Hazardous Substances in Electrical and Electronic Equipment Regulations 2012 (UK RoHS)
EN IEC 63000: 2018 & BS EN IEC 63000: 2018
Regulation (EC) No 1907/2006 (REACH)
2006/66/EC & 2013/56/EU (EU Battery Directive)
The Batteries and Accumulators (Placing on the Market) Regulations 2008 (UK Battery Regulations)
94/62/EC (EU Packaging Directive)
The Packaging (Essential Requirements) Regulations 2015 (UK Packaging Regulations)
(EU) 2019/1021 (EU POPs)
The Persistent Organic Pollutants Regulations 2007 (UK POPs)
2012/19/EU (EU WEEE) ANNEX V
The Waste Electrical and Electronic Equipment Regulations 2013 (UK WEEE) SCHEDULE 11 PART 2
China RoHS (Decree No. 32 of the Chinese Ministry of Industry and Information Technology)

Test Methods : See detailed evaluation contents

1.2 Evaluation Location

Evaluation Location : Reliability Laboratory of Huawei Technologies Co., Ltd.

Address : No.2, New City Avenue, Songshan Lake Sci. & Tech. Industry Park, Dongguan, 523808, P.R.C

2 Product Photo



3 Review of Documents of Conformity

According to European Standard EN IEC 63000: 2018 and UK Standard BS EN IEC 63000: 2018, the manufacturer should collect supplier declarations and/or contractual agreements, and/or material declarations and/or analytical test results from all suppliers. As per Huawei's requirements of material compliance, all suppliers should sign the supplier declarations (*Quality and Environment Assurance Agreement* and *Indemnity Agreement for Quality and Environment Problems of Supplier's Materials* and/or provide *Declaration of Non-use of Restricted Substances* which declare suppliers' products meet Huawei's environmental requirement, including the restricted substances requirements of EU RoHS, REACH, packaging directive, battery directive, POPs and Proposition 65 of California) and provide MCD (Material Composition Declaration) and the test reports of high risk materials to prove that their products comply with the requirements of Huawei.

In the process of environmental compliance evaluation, all suppliers' documents were evaluated according to Huawei's requirements, and all results were described in table below.

Table 1 Evaluation Results of Documents of Conformity

Material Descriptions	Reason of Non-compliance	Conclusion
All Materials	NA	Complies

Remark: NA = Not Applicable

4 RoHS Evaluation of Product

4.1 Evaluation of Materials / Samples

According to the European Standard EN IEC 63000: 2018 and UK Standard BS EN IEC 63000: 2018, the high-risk materials should be tested during the RoHS certification process and all materials (the non-risk materials and high-risk materials) were evaluated according to Huawei’s requirements (See clause 3). As per the Directive 2011/65/EU and amendments (EU RoHS Directive), and UK RoHS, the evaluation results were summarized in table below based on the product’s Bill of Materials (BOM) and tested results provided by the applicant.

(1) High Risk Materials / Samples Information

Table 2 Evaluation results of high risk materials / samples for RoHS

Item	Evaluation of High Risk Materials / Samples ^{#1}		
High Risk Material Information	Amount		
	High Risk Samples in Product ^{#2}	Tested Samples	Failed Samples
	10	10	0
Result ^{#3}	Complies		

Remarks:

#1 : Evaluation results were based on the configuration of the product (See Annex II).

#2 : As per Huawei’s “Guide to Grading RoHS Compliance Risk Levels of Materials”, and “Annex D in GB/T 26572”, the high risk materials include solder (Pb), plating layer (Pb, Cr(VI)), plastic colorant (Pb, Cd and Cr(VI)), ABS (Acrylonitrile Butadiene Styrene) plastic (PBDE), PVC (Polyvinyl Chloride) plastic (Pb, Cd), PP (Polypropylene) plastic (PBDE), PET (Polyester Terephthalate) plastic (PBDE), PBT (Polybutylene Terephthalate) plastic (PBDE), coatings (Pb), cable jacketing and other soft plastics (phthalate substances DEHP, BBP, DBP and DIBP) and alloy (Pb, Cd and Cr(VI)).

#3 : The results based on the evaluation results and the exemptions in EU RoHS & UK RoHS, and all exemptions applied to the evaluated product materials were taken as “Pass” for the evaluation results.

(2) Information of Failed Sample

According to the information from environmental attributes of parts in Huawei PDM System, MCD and test report in Huawei Insight system submitted by suppliers and applicant, the contents of restricted substances in EU RoHS and UK RoHS are listed in table below.

Table 3 Contents of Restricted Substances in Failed Sample

Material Descriptions	Report No.	Content of Restricted Substances (ppm)									
		Cd	Pb	Hg	Cr(VI)	PBB	PBDE	DEHP	DBP	BBP	DIBP
-	-	-	-	-	-	-	-	-	-	-	-

Remark:

ppm = parts per million

4.2 Test Items and Methods of the High Risk Materials

As per the information provided by the applicant, the high risk materials were tested by the following methods.

Table 4 Test Methods of High Risk Materials for RoHS

Testing Item	Test Method
Cadmium (Cd)	With reference to EN/IEC 62321-5, by acid digestion and determined by ICP-OES
Lead (Pb)	
Mercury (Hg)	With reference to EN/IEC 62321-4, by acid digestion and determined by ICP-OES
Hexavalent chromium [Cr(VI)]	With reference to EN/IEC 62321-7-1& EN/IEC 62321-7-2 by solvent extraction and determined by UV-VIS
Polybrominated biphenyls (PBB)	With reference to EN/IEC 62321-6, by solvent extraction and determined by GC/MS
Polybrominated diphenyl ethers (PBDE)	
Bis(2-ethylhexyl) phthalate (DEHP)	With reference to EN/IEC 62321-8, by solvent extraction and determined by GC/MS
Butyl benzyl phthalate (BBP)	
Dibutyl phthalate (DBP)	
Diisobutyl phthalate (DIBP)	

4.3 RoHS Requirements

The limits of restricted substances were quoted from EU RoHS and UK RoHS for homogeneous material.

Table 5 Limits of Restricted Substances in EU RoHS and UK RoHS

Restricted Substances	Limits
Cadmium (Cd)	0.01% (100 ppm)
Lead (Pb)	0.1% (1000 ppm)
Mercury (Hg)	0.1% (1000 ppm)
Hexavalent chromium [Cr(VI)]	0.1% (1000 ppm)
Polybrominated Biphenyls (PBB)	0.1% (1000 ppm)
Polybrominated Diphenyl Ethers (PBDE)	0.1% (1000 ppm)
Bis(2-ethylhexyl) phthalate (DEHP)	0.1% (1000 ppm)
Butyl benzyl phthalate (BBP)	0.1% (1000 ppm)
Dibutyl phthalate (DBP)	0.1% (1000 ppm)
Diisobutyl phthalate (DIBP)	0.1% (1000 ppm)

5 REACH Evaluation

5.1 REACH Requirements of article in product

5.1.1 SVHC Requirements

In accordance with paragraph 2 and 4 of Article 7 in Regulation (EC) No 1907/2006(REACH), any producer or importer of articles shall notify ECHA, if a substance meets the criteria in Article 57 and is identified in accordance with Article 59(1) of the Regulation, if (a) the substance in the Candidate List is present in those articles in quantities totalling over one tonne per producer or importer per year; and (b) the substance in the

Candidate List is present in those articles above a concentration of 0.1% weight by weight. The following information has to be submitted for notification:

- a. the identity and contact details of the producer or importer;
- b. the registration number(s), if available;
- c. the identity of the substance;
- d. the classification of the substance(s);
- e. the classification of the substance(s) and of the uses of the article(s);
- f. the tonnage range of the substance(s).

As per article 33 of REACH, recipients of product must be provided with sufficient information, as a minimum, the name of that substance, to allow safe use if the concentration of any SVHC is above 0.1% weight by weight.

The SVHC (Substances of very high concern) are listed on ECHA (European Chemical Agency) website (<https://echa.europa.eu/candidate-list-table>).

5.1.2 REACH Annex XVII Requirements

In accordance with article 67 of REACH, a substance on its own, in a mixture or in an article, for which Annex XVII contains a restriction shall not be manufactured, placed on the market or used unless it complies with the conditions of that restriction. According to article 68, when there is an unacceptable risk to human health or the environment, arising from the manufacture, use or placing on the market of substances, which needs to be addressed on a Community-wide basis, Annex XVII shall be amended in accordance with the procedure referred to in Article 133(4) by adopting new restrictions, or amending current restrictions in Annex XVII.

5.2 REACH SVHC Evaluation

5.2.1 SVHCs in a concentration above 0.1% weight by weight of article

According to the supplier declarations and/or contractual agreements, the MCD and test report in Huawei Insight System submitted by suppliers and the applicant, the SVHC (Substances of Very High Concern) in a concentration above 0.1% weight by weight of "article" in the product (including battery and packaging) are listed as below.

Table 6 SVHCs in a concentration above 0.1% weight by weight

SVHCs in a concentration above 0.1% weight by weight	CAS No.
1,2-DIMETHOXYETHANE	110-71-4
1,3,5-TRIGLYCIDYL-S-TRIAZINETRIONE	2451-62-9
HEXAHYDROMETHYLPHTHALIC-ANHYDRIDE	25550-51-0
LEAD	7439-92-1

Remarks:

1. The results were based on the configuration of the product (See Annex II).

2. "Article" in product means an object which during production is given a special shape, surface or design which determines its function to a greater degree than does its chemical composition (According to Regulation (EC) No 1907/2006). The limit of 0.1% weight by weight applies to every article in the product. The results were calculated to an article defined by decision C-106/14 of EuGH of 10th September 2015.

5.2.2 Conclusion

According to specified evaluation processes in this report, SVHC in candidate list promulgated by ECHA, which are defined in article 57 of REACH, are listed in table 6.

5.3 Evaluation of REACH Annex XVII

5.3.1 Evaluation Results of REACH Annex XVII

The evaluation of restricted substances was based on the statistic of material / sample from the historical data, and the supplier was evaluated by the material categories, tested data, and so on. All suppliers should provide supplier declarations and/or sign contractual agreements to prove that their products complied with the requirements of REACH Annex XVII (if applicable). As per the data from Huawei Insight system, test report, MCD and supplier declarations provided by supplier, and according to the requirements of REACH Annex XVII of restricted substances (if applicable), the contents of restricted substances in material or sample are described in table below.

Table 7 Contents of Restricted Substances in REACH Annex XVII

Material Descriptions	Restricted Substances	Limit	Content in material / sample
All Materials	Monomethyl – tetrachlorodiphenylmethane (Ugilec 141)	Prohibited	ND
All Materials	Monomethyl-dichloro-diphenyl methane (Ugilec 121, Ugilec 21)	Prohibited	ND
All Materials	Monomethyl - dibromo - diphenylmethane, bromobenzyl toluene (DBBT)	Prohibited	ND
All Materials	Dimethyl fumarate (DMF)	0.1ppm	ND
All Materials	Asbestos fiber	Prohibited	ND
All Materials	Organotin compounds	total content < 1000 ppm	ND
All Materials	Benzene	Prohibited	ND
All Materials	Polychlorinated terphenyls and their derivatives (PCTs)	50ppm	ND
Dye or colorant for plastics, textiles, leather products	Azo dyes	30ppm	ND
Direct and long contact with the skin of the electroplating, corrosion-resistant alloy materials	Nickel and its compounds	0.5 µg/cm ² / week	ND

textiles, leather products	Nonylphenol (NP) Nonylphenol polyoxyethylene ether (NPEO)	100ppm	NA
textiles	Tris (2,3-dibromopropyl) phosphate (TRIS)	Shall not be used	NA
textiles	Tri- (aziridiny) phosphine oxide (TEPA)	Shall not be used	NA
Wooden packaging material	Arsenic and its compounds	Shall not be used	ND
Wooden packaging material	Creosote, naphthalene oil, anthracene oil, tar acid, alkaline low temperature tar etc.	Shall not be used	ND
Rubber or plastic material on the exterior or user contact surface of the product	Polycyclic Aromatic Hydrocarbons (PAHs)	Single PAHs substance (BaP;BeP;BaA;BbFA;BjFA;BkFA;CHR;DBAhA;Benzo [g,h,i]perylene;Indeno[1,2,3-cd]pyrene) < 1ppm	ND
Thermal paper	Bisphenol A	200ppm	NA
All materials	Phenylmercury	100ppm (the concentration of mercury)	ND

Remark: The evaluation results were based on the configuration of the product (See Annex II).

5.3.2 Conclusion

As per the results as above (Clause 5.3.1), the contents of restricted substances in submitted sample comply with the requirements of REACH Annex XVII (if applicable).

6 Evaluation of Packaging Material

6.1 Requirements of packaging material for restricted substances

According to EU Packaging Directive (94/62/EC) & UK Packaging Regulations (The Packaging (Essential Requirements) Regulations 2015), the sum of contents of restricted substances ((Cd, Pb, Hg and Cr (VI)) in packaging material (such as packaging, instruction, guideline and other packaging materials in medium) should be less than 100ppm.

6.2 Evaluation Results of Packaging Material

From the supplier declarations and/or contractual agreements and the MCD in Huawei Insight system and the test report submitted by suppliers and applicant, the contents of restricted and notification substances for Packaging Directive in packaging material are listed in table below.

Table 8 Contents of Restricted Substances in Packaging Material

Material Descriptions	Report No.	Content of Restricted Substances (ppm)				
		Cd	Pb	Hg	Cr(VI)	Sum
All materials	-	ND	ND	ND	ND	<100
Conclusion		Complies				

Remark:

ppm = parts per million

ND = Not detected (Less than the method limits for the test lab)

7 Evaluation of Battery

7.1 Requirements of battery for restricted substances

According to EU Battery Directive (2006/66/EC & 2013/56/EU) and UK Battery Regulations (The Batteries and Accumulators (Placing on the Market) Regulations 2008), EU and UK shall prohibit the placing on the market of: a) all batteries or accumulators, whether or not incorporated into appliances, that contain more than 0,0005 % of mercury by weight; and that contain more than 0,002 % of cadmium by weight. b) All batteries containing more than 0,004 % lead, shall be marked with the chemical symbol for the metal concerned: Pb.

7.2 Evaluation Results of Battery

According to the supplier declarations and/or contractual agreements and the MCD in Huawei Insight system and the test report submitted by suppliers and applicant, the contents of restricted substances for battery directive in battery are listed in table below.

Table 9 Contents of Restricted Substances in Battery

Material Descriptions	Report No.	Content of Restricted Substances (ppm)	
		Cd	Hg
Battery	-	ND	ND
Conclusion		Complies	

Remark:

ppm = parts per million

ND = Not detected (Less than the method limits for the test lab)

8 POPs Evaluation

8.1 Requirements of POPs

According to EU POPs Regulation (EU) 2019/1021 & UK POPs (The Persistent Organic Pollutants Regulations 2007), the manufacturing, placing on the market and use of substances listed in Annex I & Annex II, whether on their own, in mixtures or in articles, shall be prohibited. Unless it complies with the following conditions:

- (a) a substance used for laboratory-scale research or as a reference standard;
- (b) a substance presented as an unintentional trace contaminant, as specified in the relevant entries of Annex I or II, in substances, mixtures or articles.

8.2 Contents of Restricted Substances

The evaluation of restricted substances was based on the statistic of material / sample from the historical data, and the supplier was evaluated by the material categories, tested data, and so on. All suppliers should provide supplier declarations and/or sign contractual agreements to prove that their products complied with the requirements of POPs Annex I (if applicable). As per the data from Huawei Insight system, test report,

MCD and supplier declarations provided by supplier, and the requirements of POPs Annex I of restricted substances (if applicable), the contents of restricted substances in material or sample are described in table below.

Table 10 Contents of Restricted Substances in POPs Annex I

Material Descriptions	Restricted Substances	Limit	Content in material / sample
All Materials	Short-chain Chlorinated Paraffins (SCCPs, C ₁₀₋₁₃)	1500ppm	ND
All Materials	Hexachlorobutadiene(HCBD)	-	ND
All Materials (except coatings)	Perfluorooctane sulfonic acid and its derivatives (PFOS)	1000ppm	ND
Coatings		1 µg/m ²	ND
All Materials	Polychlorinated Biphenyls (PCB)	Shall not be used	ND
All Materials	Polychlorinated naphthalenes (PCNs)	Shall not be used	ND
All Materials	Hexabromocyclododecane (HBCDD)	100ppm	ND
All Materials	PFOA or any of its salts	25ppb	ND
All Materials	PFOA-related compound or a combination of PFOA-related compounds	1ppm	ND
Packaging Materials, Transport Materials	The restrictions on the use of pesticides	Shall not be used	ND
All Materials	Pentachlorophenol and its salts and esters	5ppm	ND

Remark: The evaluation results were based on the configuration of the product (See Annex II).

8.3 Conclusion

As per the results as above (Clause 5.2.2), the contents of restricted substances in submitted sample comply with the requirements of POPs Annex I (if applicable).

9 WEEE 3R (Recovery, Recycling & Reuse) Evaluation

9.1 Preparation of Product 3R Evaluation

According to Article 8 and Annex VII of EU WEEE (Directive 2012/19/EU) and the DEFRA document of UK WEEE (The Waste Electrical and Electronic Equipment Regulations 2013), the WEEE contains the following substances, mixtures and components have to be removed and be separately treated in table below.

Table 11 Results of Separately Treated Materials and Components for Evaluated Product

Descriptions of Parts and Materials	Remarks	Quantity
Polychlorinated biphenyls (PCB) containing capacitors	In accordance with Council Directive 96/59/EC of 16 September 1996 on the disposal of polychlorinated biphenyls and polychlorinated	0

	terphenyls (PCB/PCT)	
Mercury containing components	Such as switches or backlighting lamps	0
Batteries	All types batteries	1
Printed Circuit Boards (PCB) or Printed Circuit Board Assemblies (PCBA)	Printed circuit boards of mobile phones generally, and of other devices if the surface of the printed circuit board is greater than 10 square centimeters	3
Components and parts containing toner and ink, including liquids, semi-liquids (gel/paste) and toner	Including the cartridges, print heads, tubes, vent chambers, and service stations and so on	0
Plastics containing Brominated Flame Retardants	All brominated Flame Retardants including PBB, PBDE, HBCDD and so on	0
Components and waste containing asbestos	-	0
Cathode Ray Tubes (CRT)	-	0
Chlorofluorocarbons (CFC), hydrochlorofluorocarbons (HCFC) or hydrofluorocarbons (HFC), hydrocarbons (HC)	-	0
Gas Discharge Lamps	-	0
Liquid Crystal Displays (LCD)	With a surface greater than 100 square centimeters, includes background illuminated displays with gas discharge lamps	0
External electric cables	Externally connected and removable	0
Components, parts and materials containing refractory ceramic fibers	Described in Commission Directive 97/69/EC adapting to technical progress Council Directive 67/548/EEC relating to the classification, packaging and labeling of dangerous substances	0
Components, parts and materials containing radioactive substances	With the exception of components that are below the exemption thresholds set in Article 3 of an Annex I to Council Directive 96/29/Euratom laying down basic safety standards for the protection of the health of workers and the general public against the dangers arising from ionizing radiation	0
Electrolyte capacitors containing substances of concern	Height > 25 mm, diameter > 25 mm or proportionately similar volume	0

9.2 WEEE 3R Calculation of Product

As per the evaluation instructions of WEEE 3R and Huawei Insight system, according to IEC/TR 62635 and actual 3R data of EEE products, the results of 3R were listed in table below:

Table 12 Results of WEEE 3R for Evaluated Product

a) SCharger-22KT-S0

Material / Part Description	Weight Ratio (%)	Recoverability Rate (%)	Reuse and Recyclability Rate (%)	Weight Ratio of Recovery (%)	Weight Ratio of Reuse & Recycling (%)
(1) Parts required selective treatment					
Power Cable	1.13%	90%	85%	1.02%	0.96%
Capacitor (containing polychlorinated biphenyls)	0.00%	90%	85%	0.00%	0.00%
PCB (Printed Circuit Board assembly)	19.03%	90%	70%	17.13%	13.32%
BFR (brominated flame retardant) plastics	0.00%	90%	0%	0.00%	0.00%
LCD (liquid crystal display)	0.00%	0%	0%	0.00%	0.00%
Electrolyte Capacitors	0.00%	0%	0%	0.00%	0.00%
(2) Parts difficult to process					
Compressors	0.00%	90%	90%	0.00%	0.00%
AC Motor	0.00%	90%	90%	0.00%	0.00%
Resin Motor	0.00%	0%	0%	0.00%	0.00%
Transformer (MWO: microwave oven transformer)	0.00%	90%	90%	0.00%	0.00%
(3) Parts with a single recyclable material					
ABS (Acrylonitrile Butadiene Styrene)	0.00%	90%	90%	0.00%	0.00%
PC (Polycarbonate)	64.23%	90%	90%	57.81%	57.81%
PET (Polyethylene Terephthalate)	0.00%	90%	90%	0.00%	0.00%
PP (Polypropylene)	1.13%	90%	90%	1.02%	1.02%
PS (Polystyrene)	0.00%	90%	90%	0.00%	0.00%
PBT (Polybutylene terephthalate)	0.00%	90%	90%	0.00%	0.00%
PVC (Polyvinyl chloride)	0.00%	90%	0%	0.00%	0.00%

POM (Polyoxymethylene)	0.48%	90%	90%	0.43%	0.43%
EP (Epoxy Resin)	0.00%	90%	0%	0.00%	0.00%
Steel	1.13%	98%	98%	1.11%	1.11%
Aluminum	2.10%	98%	98%	2.06%	2.06%
Copper	2.74%	98%	98%	2.69%	2.69%
Rubber	0.00%	90%	0%	0.00%	0.00%
Fiberglass	0.00%	80%	80%	0.00%	0.00%
Others	8.03%	60%	60%	4.82%	4.82%
Total	100.00%	-	-	88.09%	84.22%

b) SCharger-7KS-S0

Material / Part Description	Weight Ratio (%)	Recoverability Rate (%)	Reuse and Recyclability Rate (%)	Weight Ratio of Recovery (%)	Weight Ratio of Reuse & Recycling (%)
(1) Parts required selective treatment					
Power Cable	1.00%	90%	85%	0.90%	0.85%
Capacitor (containing polychlorinated biphenyls)	0.00%	90%	85%	0.00%	0.00%
PCB (Printed Circuit Board assembly)	19.67%	90%	70%	17.70%	13.77%
BFR (brominated flame retardant) plastics	0.00%	90%	0%	0.00%	0.00%
LCD (liquid crystal display)	0.00%	0%	0%	0.00%	0.00%
Electrolyte Capacitors	0.00%	0%	0%	0.00%	0.00%
(2) Parts difficult to process					
Compressors	0.00%	90%	90%	0.00%	0.00%
AC Motor	0.00%	90%	90%	0.00%	0.00%
Resin Motor	0.00%	0%	0%	0.00%	0.00%
Transformer (MWO: microwave oven transformer)	0.00%	90%	90%	0.00%	0.00%
(3) Parts with a single recyclable material					
ABS (Acrylonitrile Butadiene Styrene)	0.00%	90%	90%	0.00%	0.00%
PC (Polycarbonate)	66.37%	90%	90%	59.73%	59.73%
PET (Polyethylene	0.00%	90%	90%	0.00%	0.00%

Terephthalate)					
PP (Polypropylene)	1.17%	90%	90%	1.05%	1.05%
PS (Polystyrene)	0.00%	90%	90%	0.00%	0.00%
PBT (Polybutylene terephthalate)	0.00%	90%	90%	0.00%	0.00%
PVC (Polyvinyl chloride)	0.00%	90%	0%	0.00%	0.00%
POM (Polyoxymethylene)	0.50%	90%	90%	0.45%	0.45%
EP (Epoxy Resin)	0.00%	90%	0%	0.00%	0.00%
Steel	1.17%	98%	98%	1.14%	1.14%
Aluminum	2.17%	98%	98%	2.12%	2.12%
Copper	2.83%	98%	98%	2.78%	2.78%
Rubber	0.00%	98%	98%	0.00%	0.00%
Fiberglass	0.00%	80%	80%	0.00%	0.00%
Others	5.13%	60%	60%	3.08%	3.08%
Total	100.00%	-	-	88.95%	84.97%

Remarks:

3R = Recovery, Reuse and Recycling

WEEE = Waste Electrical and Electronic Equipment

The evaluation results were based on the configuration of the product (See Annex II).

9.3 WEEE 3R Conclusion

According to the evaluation process of WEEE 3R described above clause 9.1.2, the below conclusion can be gotten in table below.

Table 13 Conclusion of WEEE 3R for Evaluated Product

Product Name		Smart Charger	
Product Category		Small IT and telecommunication equipment (no external dimension more than 50 cm)	
Reuse/recycling/recovery (3R)		Recovery (%)	Reuse & Recycling (%)
Evaluation	SCharger-22KT-S0	88.09%	84.22%
Result	SCharger-7KS-S0	88.95%	84.97%
3R Minimum targets in WEEE for the Product		75%	55%
3R Compliance for the Product		Complies	Complies

9.4 Sketch Figure of Sample Disassembly

The disassembly procedure taken here is in accordance with the treatment requirements under EU WEEE & UK WEEE, and based on economic and efficiency factor, disassembly tools, and current state of the art of recycling and recovery technology. The detailed information for sample disassembly can be described as below in Figure 1.

Figure 1 Sketch Figure of Evaluated Sample Disassembly

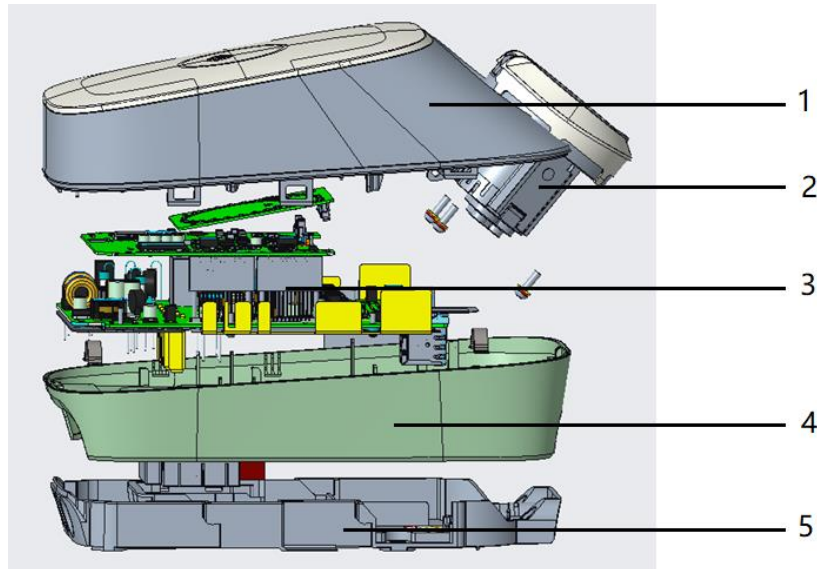

Remarks: (All information is from the installation instruction)

- (1) Upper shell (2) Socket (3) Board (4) Lower shell (5) Backplane

9.5 WEEE 3R Requirements

As per EU WEEE & UK WEEE, all products sold in EU & UK should comply with the requirements of recovery, recycling and reuse (3R) for their design. Detailed requirements for 3R are described in table below.

Table 14 Minimum targets of WEEE 3R for different EEE categories

Category No.	EEE Category	Rate of Recovery	Rate of Reuse & Recycling
1	Temperature exchange equipment	85%	80%
2	Screens, monitors, and equipment containing screens having a surface greater than 100 cm ²	80%	70%
3	Lamps	80%	-
4	Large equipment (any external dimension more than 50 cm)	85%	80%
4a	Large equipment excluding photovoltaic panels	85%	80%
4b	Photovoltaic panels	85%	80%
5	Small equipment (no external dimension more than 50 cm)	75%	55%
6	Small IT and telecommunication equipment (no external dimension more than 50 cm)	75%	55%

9.6 WEEE 3R Definition

According to EU WEEE& UK WEEE, Reuse, Recycling & Recovery Rate using in the report are calculated as following formulas.

$$\text{Recovery Rate (\%)} = \frac{\text{Reuse \& Recycling Weight} + \text{Energy Recovery Weight}}{\text{Product Total Weight}} \times 100\%$$

$$\text{Reuse \& Recycling Rate (\%)} = \frac{\text{Reuse \& Recycling Weight}}{\text{Product Total Weight}} \times 100\%$$

Remark: Total weight of the product includes the main product and accessories weight.

Annex I China RoHS Hazardous Substances Information Evaluation

According to China RoHS (the Administrative Measures for the Restriction of the Use of Hazardous Substances in Electrical and Electronic Products on Jan 21, 2016, with it coming into effect on July 1, 2016., Decree No. 32 of the Chinese Ministry of Industry and Information Technology), a Hazardous Substance table must also be supplied with the product that lists each part that is out of compliance. As per the evaluation process and the data in Huawei Insight system, the below table was made for the product and its fittings.

Table 1 Hazardous Substances Table in Product

部件名称 Part Descriptions	有害物质 Hazardous Substances					
	镉 Cd	铅 Pb	汞 Hg	六价铬 Cr(VI)	多溴联苯 PBB	多溴二苯醚 PBDE
印制电路板组件 PCBA	○	×	○	○	○	○
电缆 Cable	○	×	○	○	○	○
金属部件 Metal Part	○	×	○	○	○	○
聚合物部件 Polymeric Part	○	○	○	○	○	○
电池 Battery	○	×	○	○	○	○

备注：本表格依据SJ/T 11364的规定编制。

Remark: The table is prepared in accordance with SJ/T 11364.

- : 表示该有害物质在该部件所有均质材料中的含量均在GB/T 26572规定的限量要求以下。
It means that the content of the restricted substances in all materials of part is less than the limit defined in GB/T 26572 and other similar directives in other countries.
- × : 表示该有害物质至少在该部件的某一均质材料中的含量超出GB/T 26572规定的限量要求。
It means that the content of the restricted substances in at least one homogenous material of part is not less than the limit defined in GB/T 26572 and other similar directives in other countries.

上表中的“×”表示这些部件适用一项或多项欧盟RoHS豁免。

The “×” in the above table indicates that one or more EU RoHS exemptions are applied in these parts.

Annex II Configuration of Product

Board list	
Board Name	Description
ES11PWRAI	Manufactured Board, 22kW, ES11PWRAI, ChargeONE AC V100R022C10
ES11CTLBA	Manufactured Board, ES11CTLBA, Europe AC charging pile 7 kW/22 kW, ChargeONE AC V100R022C10
ES11LEDAA	Manufactured Board, ES11LEDAA, European AC charging post lamp panel, ChargeONE AC V100R022C10

EN61CTLWA04	Manufactured Board, EN61CTLWA04
Subassembly list	
Subassembly Name	Description
CHD-M1ID01	Access Control Accessories, ID Card, ID card

END